



Capillary Ultrafiltration Module

HYDRAcap[®] 80

Performance[†]	Filtrate Flow: Filtrate Turbidity: Virus removal: Bacteria removal:	16.3 – 39.5 gpm (3.7 – 9.0 m ³ /h) ≤ 0.07 NTU ≥ 4 log ≥ 4 log
Type	Configuration: Membrane Polymer: Nominal Membrane Area: Fiber Dimensions: Pore size:	Capillary Ultrafiltration Module Hydrophilic Polyethersulfone 670 ft ² (62.2 m ²) ID 0.031" (0.8 mm), OD 0.055" (1.4 mm) 0.02 micron
Application Data[‡]	Typical Filtrate Flux Range: Maximum Applied Feed Pressure: Maximum Transmembrane Pressure: Maximum Backwash Transmembrane Pressure: Instantaneous Chlorine Tolerance: Instantaneous Hydrogen Peroxide Tolerance: Maximum Chlorine Exposure: Maximum Instantaneous Feed Turbidity: Maximum Operating Temperature: pH Operating Range: Cleaning pH Range: Operating Mode:	35 – 85 gfd (59 – 145 l/m ² /h) 73 psig (5 bar) 20 psig (1.4 bar) 20 psig (1.4 bar) 100 ppm 200 ppm 100,000 ppm-hrs 100 NTU 104 °F (40 °C) 4.0 - 10.0 1.5 – 13.0 Inside to Outside Filtration Direct flow or Crossflow

Typical Process Conditions

Backwash Flux:	100 – 150 gfd (170 – 255 l/m ² /h)
Backwash Duration:	30 – 60 seconds
Backwash Frequency:	20 – 60 minutes
Chemical Enhanced Backwash Frequency:	0 – 4 times per day
Chemical Enhanced Backwash Duration:	1 – 30 minutes
Disinfection Chemicals:	NaOCl, H ₂ O ₂ , ClO ₂ or NH ₂ Cl
Cleaning Chemicals:	NaOH, HCl, H ₂ SO ₄ , or Citric Acid

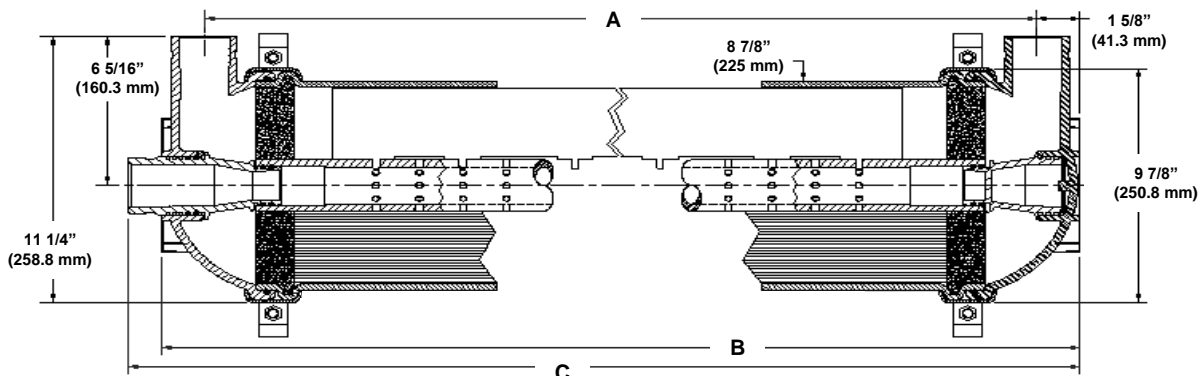

A, inches (mm)	B, inches (mm)	C, inches (mm)	Pipe connections	Weight, lbs. (kg) ave.
83 (2108)	86 1/8 (2188)	87 1/4 (2216)	2" Victaulic	120 (54)

Certifications: NSF61, CDPH, and ETV-NSF Verification

^{*} At 68°F (20°C).

^{**} For 15 minutes or less.

[†] Typical module performance for most feedwaters.

[‡] The limitations shown here are for general use. The values may be more conservative for specific projects to ensure the best performance and longest life of the membrane.

Notice: Weight stated is shipping weight including 1L of a 0.95% solution of sodium bisulfite preservative. Hydranautics also offers HYDRAcap[®]80-NON, which is a dummy module with no potting or fiber.

Hydranautics believes the information and data contained herein to be accurate and useful. The information and data are offered in good faith, but without guarantee, as conditions and methods of use of our products are beyond our control. Hydranautics assumes no liability for results obtained or damages incurred through the application of the presented information and data. It is the user's responsibility to determine the appropriateness of Hydranautics' products for the user's specific end uses.

